

Installation Instructions for Edwards AdaptaLight™ Heavy Duty Industrial Stackable Beacons

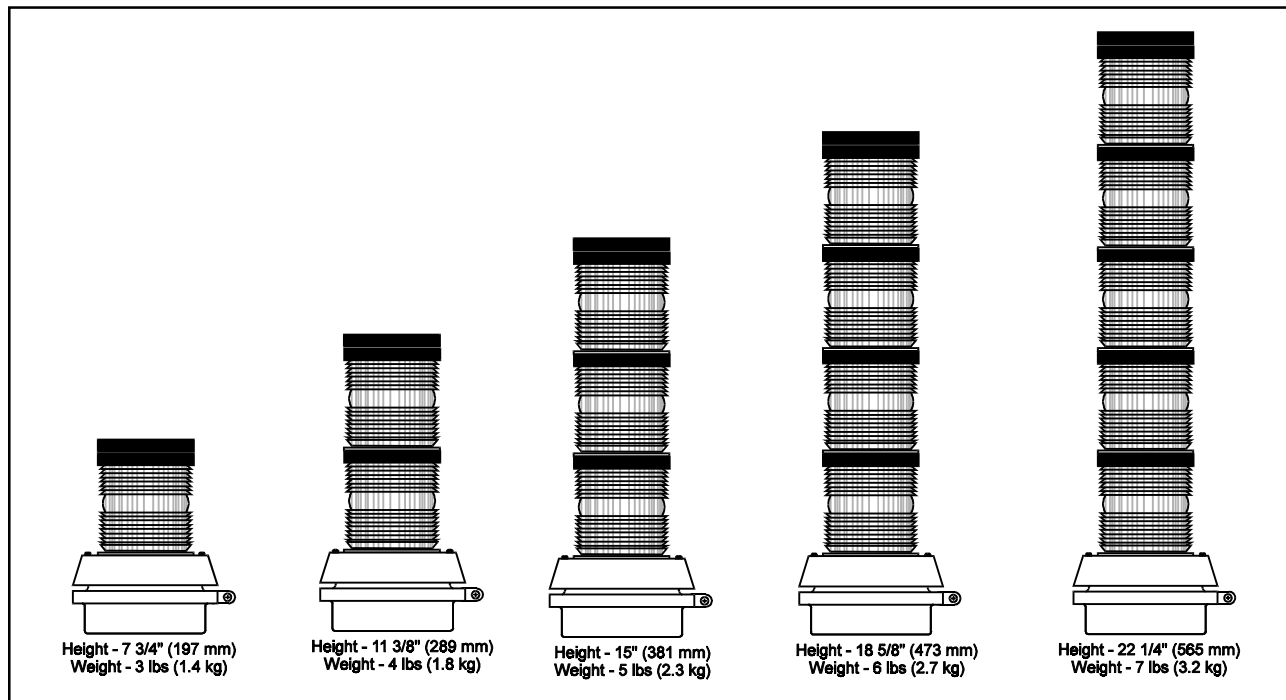

Figure 1. Dimensions

Description

Edwards AdaptaLight Series 101 Stackable Beacon is a unique signaling appliance which can contain up to five modules, stacked onto a single AdaptaLight Base Unit (as illustrated above). AdaptaLight Modules are available in Steady-On Incandescent (101SIN), Steady-On Halogen (101SINH), Steady-On LED (101SLED), Flashing Incandescent (101FIN), Flashing Halogen (101FINH), Flashing LED (101FLED), or Strobe (101ST). Up to five modules can be used in any position in the AdaptaLight Stackable Beacon.

The 9 watt halogen bulb is rated by the manufacturer at 52 lumens. The 12 watt halogen bulb is rated by the manufacturer at 70 lumens.

The AdaptaLight base unit (101BS) contains a mini pulsating horn rated 85 dB at 10 feet (3.05 m). This horn can operate as a sixth independent signal or with any one of the stacked modules. The base unit has a screw-type terminal strip for positive hard wiring. Each module in the stack is electrically interconnected through solid copper busses and mating contacts to withstand vibration. Each is positively connected to the one below it by a solid through-bolt for mechanical integrity.

AdaptaLight is UL listed and CSA certified for direct surface or pipe mounting in non-hazardous dust and weatherproof applications. The AdaptaLight may be mounted vertically with lenses facing up or with lenses facing down (on ceiling). The AdaptaLight is not suitable for weatherproof installations when mounted with the lenses facing down. ***The AdaptaLight must never be mounted horizontally.*** Assemble and install in accordance with these instructions.

The AdaptaLight modules have double fresnel polycarbonate lenses available in a variety of colors, each providing a 360° non-shadowed light pattern.

Installation

CAUTION

This equipment must be installed by a qualified electrician in accordance with applicable standards. Do not connect power until instructed to do so.

1. Mount the base vertically either facing up or down using one of the following procedures (Figures 2 and 3).

NOTE: For indoor applications, the base may be direct surface mounted, mounted on a 4" (102 mm) octagon box, or mounted on 1/2" (13 mm) NPT conduit. For outdoor (weatherproof) applications, the base must be conduit mounted vertically facing up.

- a. Loosen the screw in the clamp ring, remove ring and set aside.

NOTE: A permanently affixed gasket is supplied on the base. Use care when handling the base unit to prevent tearing of the gasket.

- b. Direct Surface Mounting (indoor installation only)

Remove the two knockouts from the bottom of the base.

Fasten the base to the surface using suitable hardware (not supplied).

- c. 4" (102 mm) Octagon Box Mounting (indoor installation only)

Remove the two knockouts from the bottom of the base.

Fasten the base to the octagon box (not supplied) by installing the screws (supplied with the box) through the knockout holes in the base.

- d. Conduit Mounting (indoor or outdoor installation)

Install a 1/2" (13 mm) NPT conduit (not supplied). Align the conduit entrance hole on the base with the conduit and rotate base until base is tightly secured.

- 2. Route incoming field wiring into the base through the conduit entrance hole.

Up to five high-intensity strobe modules, and/or flashing halogen or LED modules, and/or steady-on halogen or LED modules can be used in any position in the stack. The terminal block labels, 1 through 5, correspond to the stacked modules with 1 being the bottom module on the stack.

Connect field wiring to the terminal block as shown in Figure 4.

Ground the AC AdaptaLights to the grounding screw (Figure 3) in accordance with applicable codes. Place the connected wires inside of the base.

Assemble the base unit and place the base gasket on top as shown in Figure 2.

- 3. To stack the modules, align the notch on the bottom of the first module with the notch on the base and press into position. Secure by tightening the slotted panhead through-bolt located on the top of the module.

NOTE: Never try to remove the through-bolt from the module.

Install the #8-32 x 3/8" (9.5 mm) plastic panhead screw in the side of the module lens (Figure 5).

Place gasket supplied with module onto the top of the module.

Continue adding modules in this manner as required.

Place the cap supplied with the base unit onto the top module ensuring the gasket is in place. Secure with an o-ring and 3/8" (9.5 mm) cap screw (supplied).

- 4. Turn on power and verify that module(s) and horn are operating properly.

Maintenance

Refer to "Specifications" for replacement parts.

CAUTION

Disconnect all power and wait 5 minutes for stored energy in strobe modules to dissipate before starting work on unit.

1. Remove the 3/8" (9.5 mm) cap screw, o-ring and cap from top of unit.
2. Remove the #8-32 x 3/8" (9.5 mm) plastic panhead screw from the side of the module lens.
3. Loosen the slotted panhead through-bolt (on top module). Do not remove the through-bolt from the module; turn the bolt approximately 30 turns.
4. Carefully remove the module and gasket.

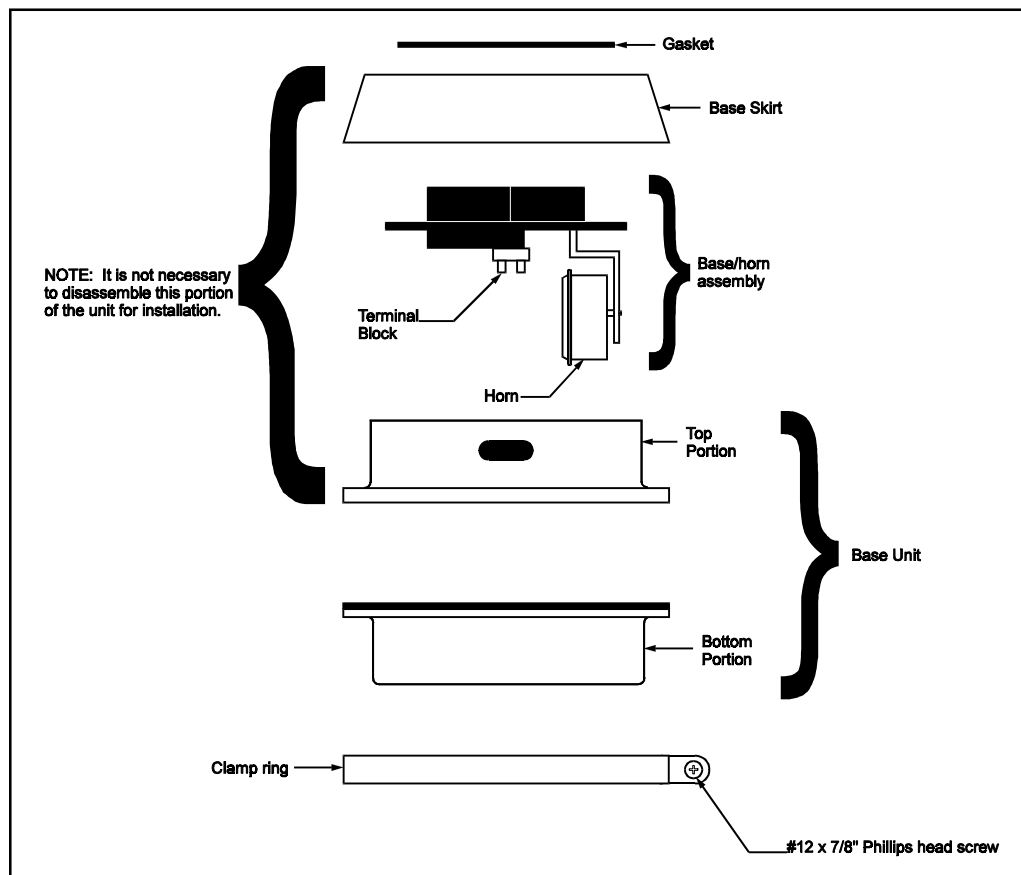

Figure 2. Catalog Series 101BS AdaptaLight Base Unit Assembly

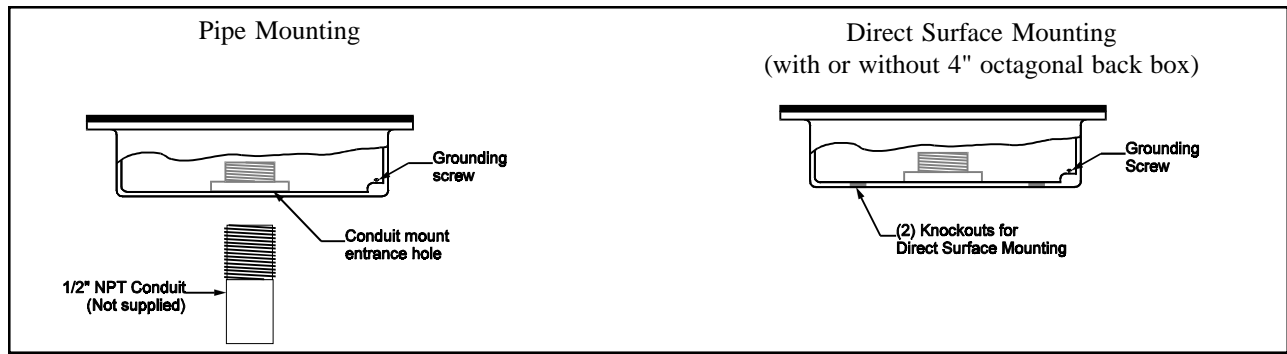

Figure 3. Mounting the Catalog Series 101BS AdaptaLight Base Unit

5. Continue to disassemble until the component to be replaced is located and replace as follows.

CAUTION

When relamping, DO NOT touch glass with bare fingers. Grasp glass with a soft, clean cloth or with packaging supplied with the replacement lamp.

6. Replace the incandescent or halogen lamp.
 - a. Reach inside module, carefully grasp the lamp and press down while turning counterclockwise to release.
 - b. Place new lamp in socket and press down while turning clockwise.
7. Replace the strobe tube.

CAUTION

Never touch glass part of strobe tube with bare hands; use a clean cloth or gloves.

- a. Reach inside module, grasp the *base* of the strobe tube and remove.
 - b. Holding the new strobe tube only by its base (if possible), insert tube in socket.
8. Replace mini pulsating horn.
 - a. Remove the screw in the clamp ring, remove ring and set aside.
 - b. Remove three phillips head screws from top of base skirt and remove the base skirt and the base/horn assembly from the top portion of the base (Figure 2).
 - c. Remove the phillips head screw securing the horn to the mounting bracket (Figure 2).
 - d. On DC models, disconnect wire leads from the terminal blocks. On AC models, disconnect wires by cutting off the wire crimp connectors.
 - e. Secure the new horn on the mounting bracket with the screw removed in step 8.c.
 - f. On DC models, connect the wires from the horn to the terminal block. On AC models, connect wires using wire nuts (not supplied).

Cleaning

The AdaptaLight module lens surfaces should be periodically dusted and cleaned with a dry soft clean cloth to maintain optimum light visibility. If necessary, the outer lenses may be cleaned with water and a mild detergent on a well rung out soft clean cloth.

Steady-On Incandescent Light Unit*			
120V AC	12V DC	24V DC	Lens Color
101SINHR-N5	101SINR-E1	101SINHR-G1	Red
101SINHA-N5	101SINA-E1	101SINHA-G1	Amber
101SINHB-N5	101SINB-E1	101SINHB-G1	Blue
101SINHG-N5	101SING-E1	101SINHG-G1	Green
101SINHM-N5	101SINM-E1	101SINHM-G1	Magenta
101SINHC-N5	101SINC-E1	101SINHC-G1	Clear
Steady-On LED Light Unit			
120V AC	24V DC	Lens Color	
101SLEDR-N5	101SLEDR-G1	Red	
101SLEDA-N5	101SLEDA-G1	Amber	
101SLEDB-N5	101SLEDB-G1	Blue	
101SLEDG-N5	101SLEDG-G1	Green	
Flashing Incandescent Light Unit*			
120V AC	12V DC	24V DC	Lens Color
101FINHR-N5	101FINR-E1	101FINHR-G1	Red
101FINHA-N5	101FINA-E1	101FINHA-G1	Amber
101FINHB-N5	101FINB-E1	101FINHB-G1	Blue
101FINHG-N5	101FING-E1	101FINHG-G1	Green
101FINHM-N5	101FINM-E1	101FINHM-G1	Magenta
101FINHC-N5	101FINC-E1	101FINHC-G1	Clear
Flashing LED Light Unit			
120V AC	24V DC	Lens Color	
101FLEDR-N5	101FLEDR-G1	Red	
101FLEDA-N5	101FLEDA-G1	Amber	
101FLEDB-N5	101FLEDB-G1	Blue	
101FLEDG-N5	101FLEDG-G1	Green	
Flashing Strobe Light Unit			
120V AC	12V DC	24V DC	Lens Color
101STR-N5	101STR-E1	101STR-G1	Red
101STA-N5	101STA-E1	101STA-G1	Amber
101STB-N5	101STB-E1	101STB-G1	Blue
101STG-N5	101STG-E1	101STG-G1	Green
101STM-N5	101STM-E1	101STM-G1	Magenta
101STC-N5	101STC-E1	101STC-G1	Clear

*H in catalog number (e.g., 101SINHR-N5) signifies halogen module.

Stackable Light Units Available

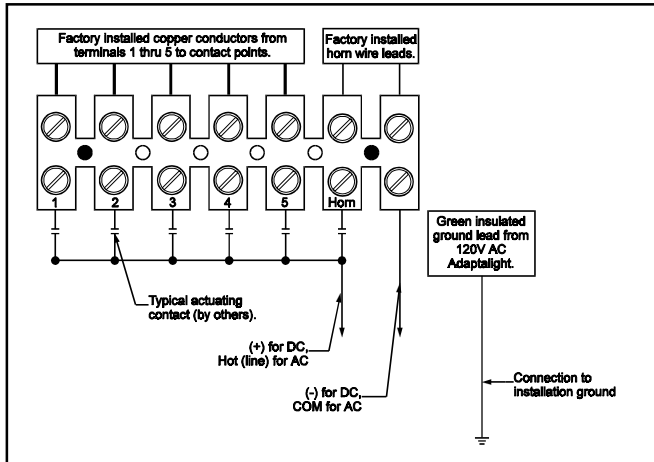

Figure 4. Wiring to the Terminal Block

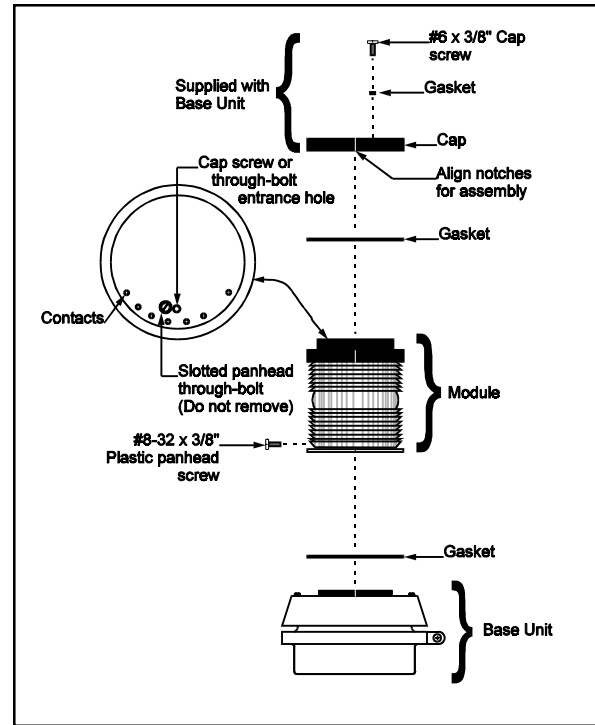

Figure 5. Stacking the Modules on AdaptaLight Base Unit

Table 1. Specifications

Catalog Number	Voltage	Current	Sound Output	Lamp Life	Light Output	Replacement Horn	Replacement Lamp**
101BS-N5	120V 50/60 Hz	0.05A	85 dB at 10 ft. (3.05 m)	--	--	123A-N5	--
101BS-E1	12V DC					122-E1	
101BS-G1	24V DC					122-G1	
101SINH*-N5	120V 50/60 Hz	0.11A	--	25,000 hr.†	70 lumens‡	--	50LMP-12WH-D***
101SIN*-E1	12V DC	1.0A		1,520 hr.†	189 lumens‡		Ind. Trade 94
101SINH*-G1	24V DC	0.32A		15,000 hr.†	52 lumens‡		50LMP-9WH-D***
101SLED*-N5	120V 50/60 Hz	0.022A	--	100,000 hr.†	--	--	--
101SLED*-G1	24V DC	0.062A					
101FINH*-N5	120V 50/60 Hz	0.11A	--	25,000 hr.†	70 lumens‡	--	50LMP-12WH-D***
101FIN*-E1	12V DC	0.10A		1,520 hr.†	189 lumens‡		Ind. Trade 94
101FINH*-G1	24V DC	0.32A		15,000 hr.†	52 lumens‡		50LMP-9WH-D***
101FLED*-N5	120V 50/60 Hz	0.022A	--	100,000 hr.†	--	--	--
101FLED*-G1	24V DC	0.062A					
101ST*-N5	120V 50/60 Hz	0.12A	--	3,000 hr.‡	300,000 peak candela	--	91B-ST
101ST*-E1	12V DC	0.5A					
101ST*-G1	24V DC	0.3A					

*Letter in this position specifies lens and LED color: A - amber, B - blue, C - clear, G - green, M - magenta, R - red.

NOTE: LED modules are only available in amber, blue, green and red.

**The LED modules are permanently installed.

***A non-halogen bulb may be used in place of the halogen bulb as follows. For 120V models, use Lamp Industry Trade No. 15T7DC and for 24V DC models, use Lamp Industry Trade No. 1692.

†Projected lamp life based on manufacturer's calculated lamp life @ 65 fpm and 50% duty cycle.

‡Calculated strobe tube life at operating power to 75% efficiency.

*Manufacturer's lumen rating.