

# EXPLOSION PROOF STROBE LIGHT



## Model FSEX

The Federal Signal Model FSEX Explosion Proof Strobe Light produces 80 high-intensity flashes per minute. This light is designed for use in alarm notification systems and is compatible with fire alarm and suppression supervised control panels and power boosters.

The FSEX is UL listed for Class 1, Division 1, Groups C & D; Class II, Division 1, Groups E, F & G; Class 1, Division 2, Groups A, B; and Class III. The FSEX is Type 4X rated.

The heavy duty, copper free cast aluminum housing is sealed with a red powder coat paint. All exposed hardware is 316 grade stainless steel.

The FSEX features a voltage in-rush limiting PCB design to provide less electrical interference with in-rush sensitive devices.

The FSEX is supplied with a pendant mount; a ceiling mount and 90-degree wall mount are optional. The installation process is simple and can be achieved by a single person. The mounting box is installed and the fixture is then threaded onto the mounting box, making an electrical connection when five threads are engaged.

## DESIGNED FOR EXPLOSION-PROOF ENVIRONMENTS

- Available in 24VDC
- 10,000 hour, strobe tube
- 3/4-inch pendant mount standard
- UL and cUL Listed, CSFM Approved
- Type 4X enclosure
- Synchronize the FSEX w/ the SSM Strobe Sync Module

| Model | Voltage | Peak In-Rush | Operating Current | Flash Rate/ Minute | Mount        | Peak Candlepower |
|-------|---------|--------------|-------------------|--------------------|--------------|------------------|
| FSEX  | 24VDC   | 3A           | 1.9 amps          | 80                 | 3/4" Pendent | 2,000,000        |



**FEDERAL SIGNAL**  
Electrical Products

VISUAL SIGNALING DEVICE (FSEX)

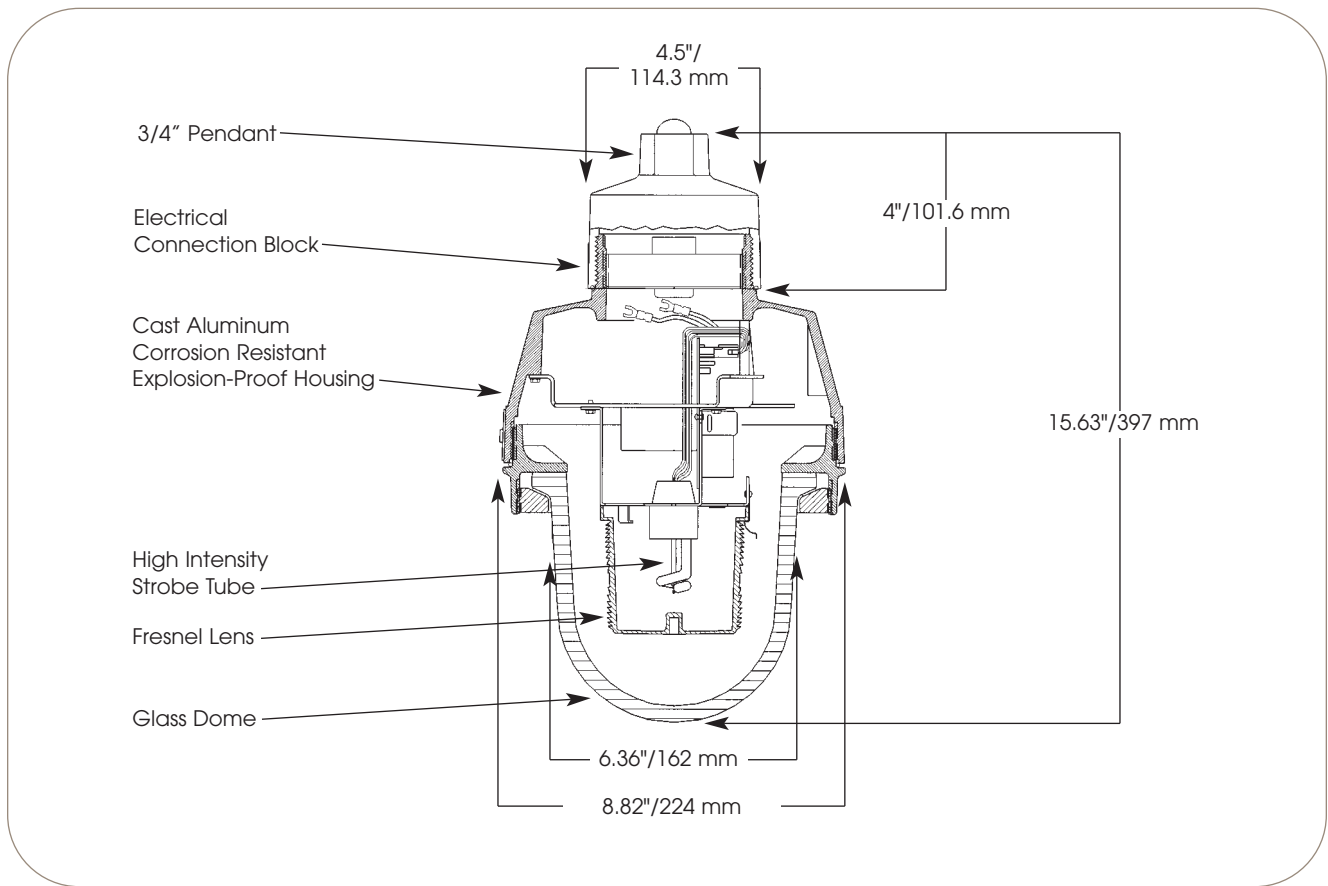

SPECIFICATIONS

|                        |                |               |
|------------------------|----------------|---------------|
| Operating Temperature: | -13°F to 149°F | -25°C to 65°C |
| Lamp Life*:            | 10,000 hours   | 10,000 hours  |
| Lamp Style:            | Strobe         | Strobe        |
| Net Weight:            | 14 lbs.        | 6.4 kg        |
| Shipping Weight:       | 18.1 lbs.      | 8.2 kg        |
| Height:                | 15.63"         | 397 mm        |
| Diameter:              | 8.82"          | 224 mm        |

HOW TO ORDER

- Specify model number
- Specify options:  
CMXC, Ceiling Mount  
WMXC, Wall Mount

DISTRIBUTOR

**The Signal Source**  
 Industry's Source for Signaling Solutions  
 P.O. Box 10330 - Palm Desert, CA 92255-033  
 Telephone 800-666-1303 - 760-341-3609  
 Fax 888-436-4277 - 760-346-0763  
 sales@thesignalsource.com - www.thesignalsource.com