

# SYNCHRONIZED EXPLOSION PROOF STROBE LIGHT



## Model FSEX-HI

The Federal Signal Model FSEX-HI Explosion Proof Strobe Light produces 80 high-intensity flashes per minute. This light is designed for use in alarm notification systems and is compatible with fire alarm and suppression supervised control panels and power boosters.

The FSEX-HI is UL listed for Class 1, Division 1, Groups C & D; Class II, Division 1, Groups E, F & G; Class 1, Division 2, Groups A, B; and Class III. The FSEX-HI is also UL1971 listed for hearing impaired applications. The FSEX is Type 4X rated.

The FSEX-HI features a voltage in-rush limiting PCB design to provide less electrical interference with in-rush sensitive devices.

To synchronize strobe lights per UL1971 purchase the SSM Synchronization Module separately.

The heavy duty, copper free cast aluminum housing is sealed with a red powder coat paint. All exposed hardware is 316 grade stainless steel.

The FSEX-HI is supplied with a pendant mount; a ceiling mount and 90-degree wall mount are optional. The installation process is simple and can be achieved by a single person. The mounting box is installed and the fixture is then threaded onto the mounting box, making an electrical connection when five threads are engaged.

## UL1971 ADA RATED AT 150 CANDELA

- Current Limited 24VDC
- 10,000 hour, strobe tube
- 3/4-inch pendant mount standard
- UL Listed, CSFM Approved
- UL 1971 Listed
- Type 4X enclosure

Model	Voltage	Peak In-Rush	Operating Current	Flash Rate/ Minute	per UL1971 Candela	Mount	Peak Candlepower
FSEX-HI	24VDC	3.0A	1.9A	80	150cd	3/4" Pendent	2,000,000



**FEDERAL SIGNAL**  
Safety and Security Systems / Industrial

*Advancing security and well-being.*

VISUAL SIGNALING DEVICE (FSEX)

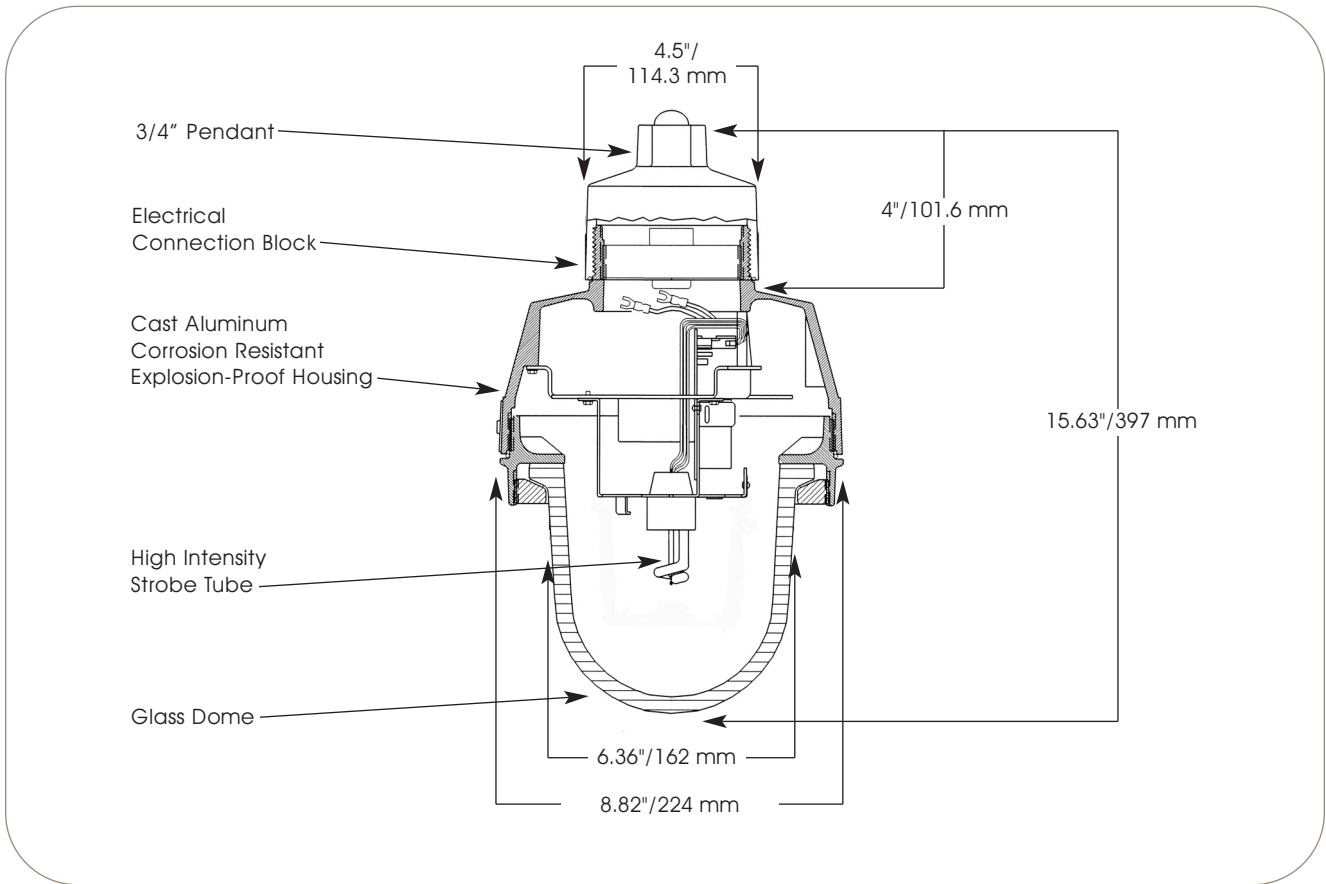

SPECIFICATIONS

Operating Temperature:	-13°F to 149°F	-25°C to 65°C
Lamp Life*:	10,000 hours	10,000 hours
Lamp Style:	Strobe	Strobe
Net Weight:	14 lbs.	6.4 kg
Shipping Weight:	18.1 lbs.	8.2 kg
Height:	15.63"	397 mm
Diameter:	8.82"	224 mm

HOW TO ORDER

- Specify model number
- Specify options:  
 CMXC, Ceiling Mount  
 WMXC, Wall Mount  
 SSM, Synchronization Module

\* Optimal hours under ideal conditions.

**DISTRIBUTOR**



**The Signal Source**  
 Industry's Source for Signaling Solutions

P.O. Box 10330 - Palm Desert, CA 92255-033  
 Telephone 800-666-1303 - 760-341-3609  
 Fax 888-436-4277 - 760-346-0763  
[sales@thesignalsource.com](mailto:sales@thesignalsource.com) - [www.thesignalsource.com](http://www.thesignalsource.com)